

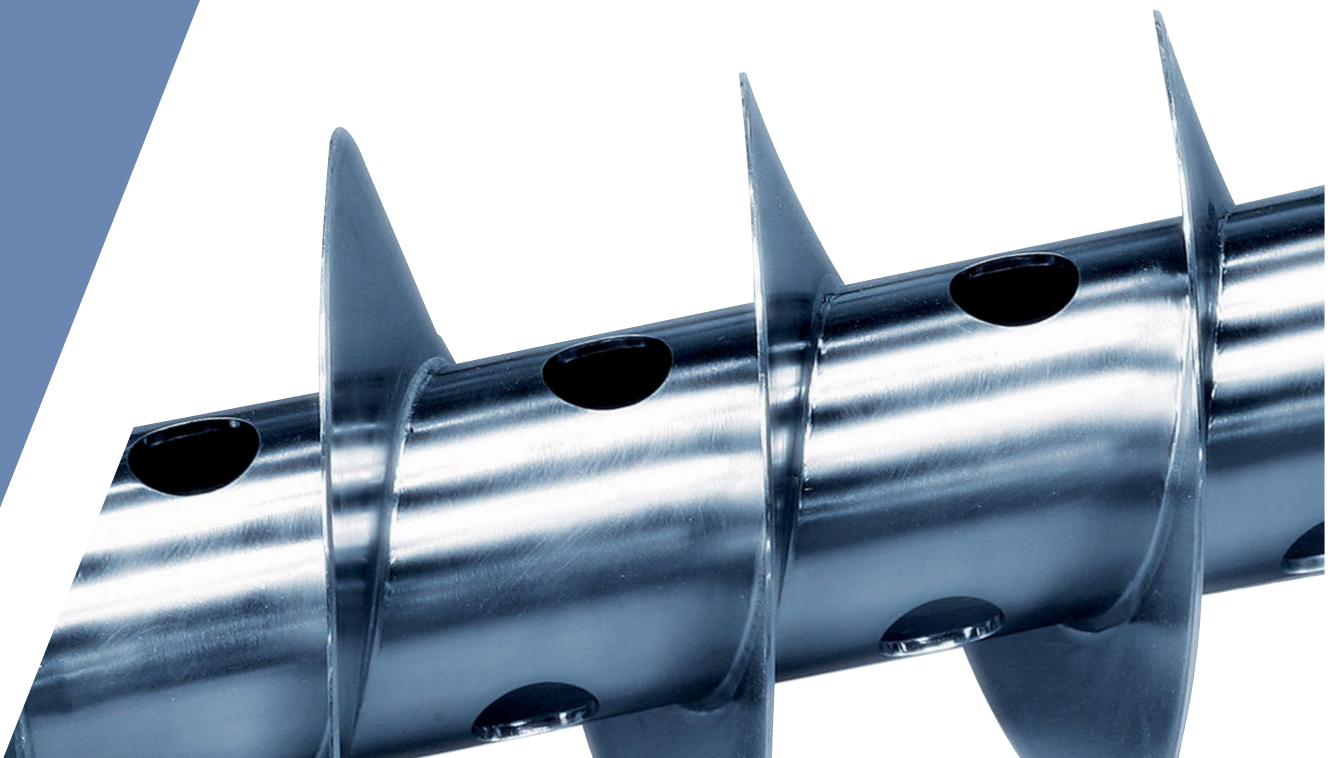

**INNOVATIVE SOLID BOWL  
DECANTER TECHNOLOGY**



# SOLID BOWL CENTRIFUGE TECHNOLOGY

Modern centrifuges are used in technical processes for the mechanical separation of mixtures of solids and liquids. Sedimentation and filtration are mechanical separation processes, in contrast to distillation, incineration and thermal drying, which are thermal separation processes. In many processes, the mechanical separation has a decisive influence on product quality, production efficiency and environmental impacts. Mechanical separation processes are found in practically all industrial sectors, including but not limited to food, chemical, pharmaceutical, biotech, mineral, and environmental processing.

## Advantages of modern centrifuges

Modern centrifuges have many advantages in comparison to other separation processes such as filtration and static settling:

- Compact designs
- Sealed construction to control odor emissions and avoid contamination of the product
- Ease of operation with continuous or automatic control systems
- Limited consumables such as filter media or filter aids

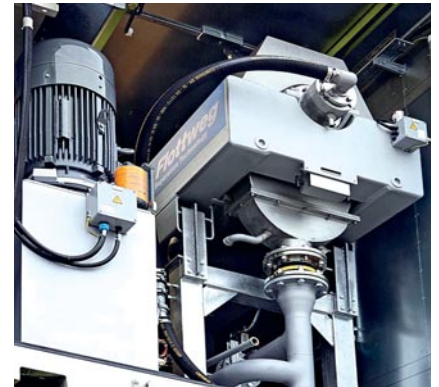

Flottweg Decanter Z4E for the processing of drilling mud



The following basic process operations are possible using solid bowl decanter centrifuges:

- Clarification of liquids
- Dewatering of sludges and suspensions
- Thickening of sludges
- Separation of three-phase mixtures,  
i.e. two immiscible liquid phases and a solid phase
- Classification of solids in a suspension according to  
particle size (wet classification)
- Sorting of solids by density

To obtain optimum results, solid bowl decanter centrifuges must be custom designed to suit specific separation processes.

Flottweg meets the needs of the vast range of applications by offering a variety of basic designs, such as the decanter, Tricanter®, Sedicanter® and Sorticanter®. Solid bowl centrifuges are used in most areas of mechanical liquid-solid separation.



The picture shows a decanter scroll

# TYPICAL APPLICATIONS

## Vegetable / Food / Animal Raw Materials

- Algae
- Animal fat
- Blood
- Brewer's yeast
- Biodiesel
- Bioethanol
- Biogas
- Casein
- Cellulose derivatives
- Coffee
- Fermentation products
- Fish meal
- Fish oil
- Fish pump water
- Fleshings
- Fruit juice
- Gelatin
- Kieselguhr
- Lactose
- Lignin
- Meat
- Molasses
- Pectin
- Potato
- Protein
- Sorbose
- Soy protein
- Spent grains
- Starch
- Stillage
- Surimi
- Vegetable extracts
- Vegetable juice
- Vegetable oils
- Vitamins
- Wine/must

## Chemical / Pharmaceutical Products

- Aluminium hydroxide
- Barium sulphate
- Basic dyes
- Calcium fluoride
- Calcium sulphate
- Color pigments
- Cryolite
- Dimethylterephthalate (DMT)
- Epoxy resin
- Fluorescents
- Iron oxide
- Latex
- Lead oxide
- Phosphate compounds
- Phosphoric acid
- Plastic derivatives/additives
- Polyethylene (HDPE)
- Polypropylene
- Polystyrene
- PVC
- Salts
- Silicate
- Sodium chloride
- Titanium dioxide
- Tricalcium phosphate
- Zinc carbonate
- Zinc oxide
- Zinc sulfate

## Minerals

- Bauxite
- Bentonite
- Calcium carbonate
- Carbide sludge
- Clay
- Copper extraction
- Graphite
- Gypsum
- Iron hydroxide
- Kaolin
- Magnesium hydroxide
- Mica
- Silica
- Silicium
- Silicon carbide

## Environmental Protection / Recycling

- Drilling mud
- Industrial wastewater
- Manure
- Municipal wastewater
- Organic waste
- Paint sludge
- Plastic sorting
- Sand and gravel wash water
- Steelwork sludge

## Mineral Oils

- Tar cleaning
- Oil sludge
- Slop oil treatment

Examples from approximately 1000 different applications

The production of biodiesel is a typical application for which centrifuges are used

# SOLID BOWL CENTRIFUGES

The basic principle of the solid bowl centrifuge has been known since the end of the 19th century. Over the course of time, technological improvements along with the availability of high strength and corrosion resistant construction materials have allowed solid bowl decanters to be applied to many processes. The utilization of electronic and electro-mechanical components for instrumentation and control has improved

the performance and availability of the machines. The basic design of a solid bowl centrifuge is relatively simple and can be customized by Flottweg for different requirements. Of all modern industrial centrifuges, solid bowl centrifuges have the broadest range of applications.



© = registered trademark in various countries

Olive oil is extracted from olives using Flottweg Tricarters®



# FLOTTWEG DECANTER CENTRIFUGES

## FEED

The product is fed through a stationary pipe into the feed zone located in the center of the scroll. The product is then accelerated circumferentially and delivered through distribution ports into the bowl.

## BOWL

The bowl has a cylindrical/conical shape and rotates at a pre-set speed optimally adjusted to the application. The slurry rotates with the bowl at the operating speed and forms a concentric layer at the bowl wall. The solids contained in the product are packed against the bowl wall by centrifugal force. The length of the cylindrical bowl section and the cone angle are selected to meet the specific requirements of an application.

## SCROLL

The scroll rotates at a slightly different speed than the bowl and conveys the separated solids toward the conical end of the bowl. This differential speed determines the residence time of the solids in the bowl. Residence time is a critical factor for cake dryness. It can be adjusted by changing the differential speed of the scroll thus providing optimal separation. If the physical properties of the product change, Flottweg Decanters can be supplied with a different scroll design or by modifying an existing scroll. Scroll pitch and single or multiple lead configurations are important design variables.

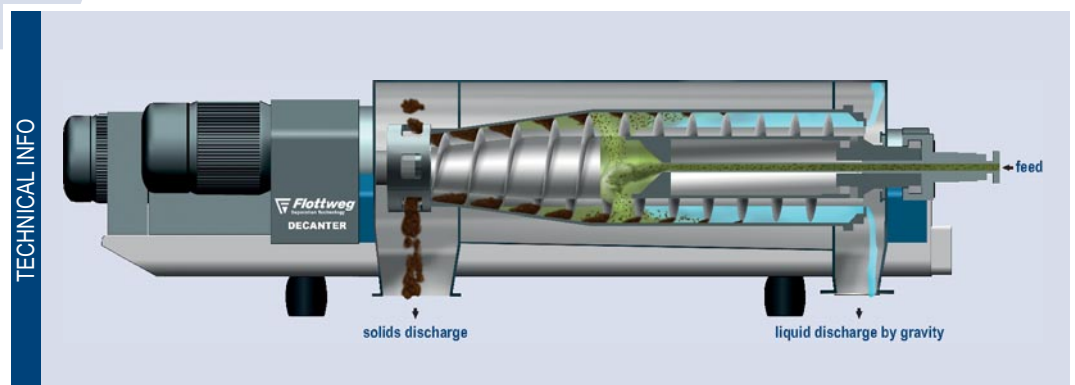

Flottweg Decanter for the liquid-solid separation with gravity overflow of the liquid phase (centrate)



The picture shows a decanter rotor with eccentric adjustable weir plates.

## SOLIDS DISCHARGE

Settled solids are ejected through ports at the conical end of the bowl into the solids housing and fall through the discharge chute.

## MATERIALS

Flottweg uses high-quality stainless steel for all product wetted areas. The bowl and scroll body are made of high-strength centrifugal Duplex stainless steel casting.

## ROTOR BEARINGS

A special selection and arrangement of bearings provides for long life and exceptional reliability. There are various lubrication systems to supply either grease or oil to bearings depending on the model and the application.

## OVERFLOW WEIRS

The clarified liquids flow to the cylindrical end of the bowl where they exit over weir plates. Easily adjustable weir plates allow for precise adjustment of the pond depth in the bowl. The liquid overflow is then collected in a centrate chamber and discharged by gravity.

## FULLY ADJUSTABLE IMPELLER (SKIMMER)

The clarified liquid can also be decanted with an impeller and discharged from the bowl under pressure. This eliminates the need for a separate chamber pump. The Flottweg Adjustable Impeller is an engineering refinement that permits quick and precise adjustment of the pond depth during operation to accommodate for changing process conditions.

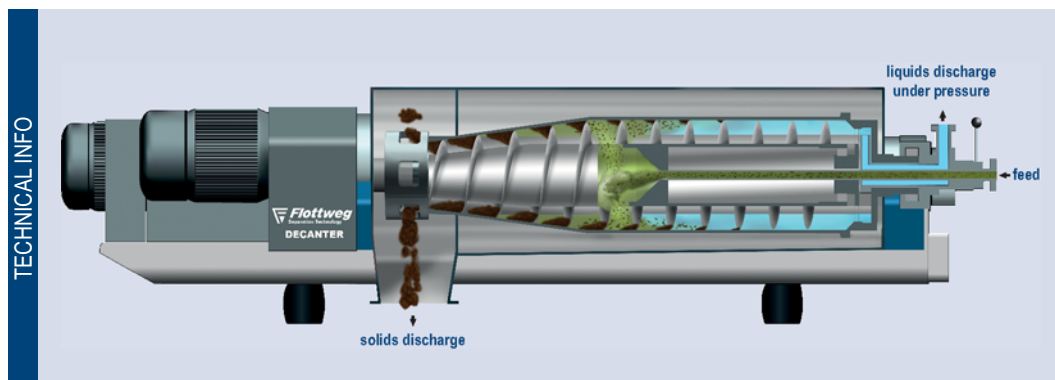

Flottweg Decanter with pressurized centrate discharge



The picture shows the position of the adjustable impeller for maximum impeller diameter

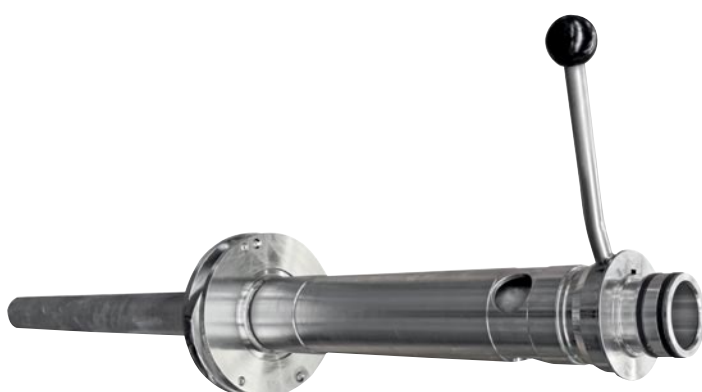

The picture shows the position of the adjustable impeller for minimum impeller diameter

# FLOTTWEG TRICANTER®

## 3-phase separation

The Flottweg Tricanter® performs a three-phase separation, i.e. the simultaneous separation of two immiscible liquids with different densities and one solid phase, provided that the solid phase is the heaviest phase. The main difference from a decanter is the separate discharge of the two liquid phases.

The Flottweg Tricanter® discharges the heavy liquid through an adjustable impeller under pressure and the light phase by gravity. The variable impeller allows for precise on-the-fly adjustment of the pond depth and liquid-liquid separation zone. This optimizes the purity of the liquids and may eliminate downstream equipment.

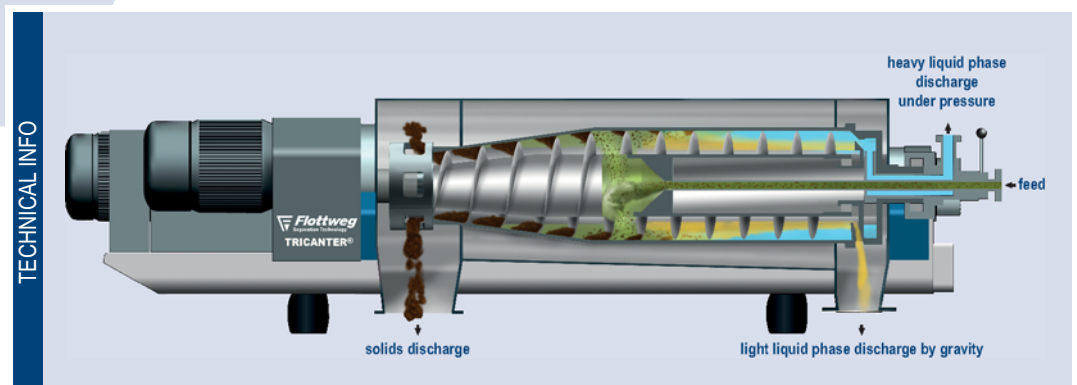

Flottweg Tricanter® (three-phase decanter)  
Discharge of the centrate: heavy liquid phase under pressure, light phase by gravity

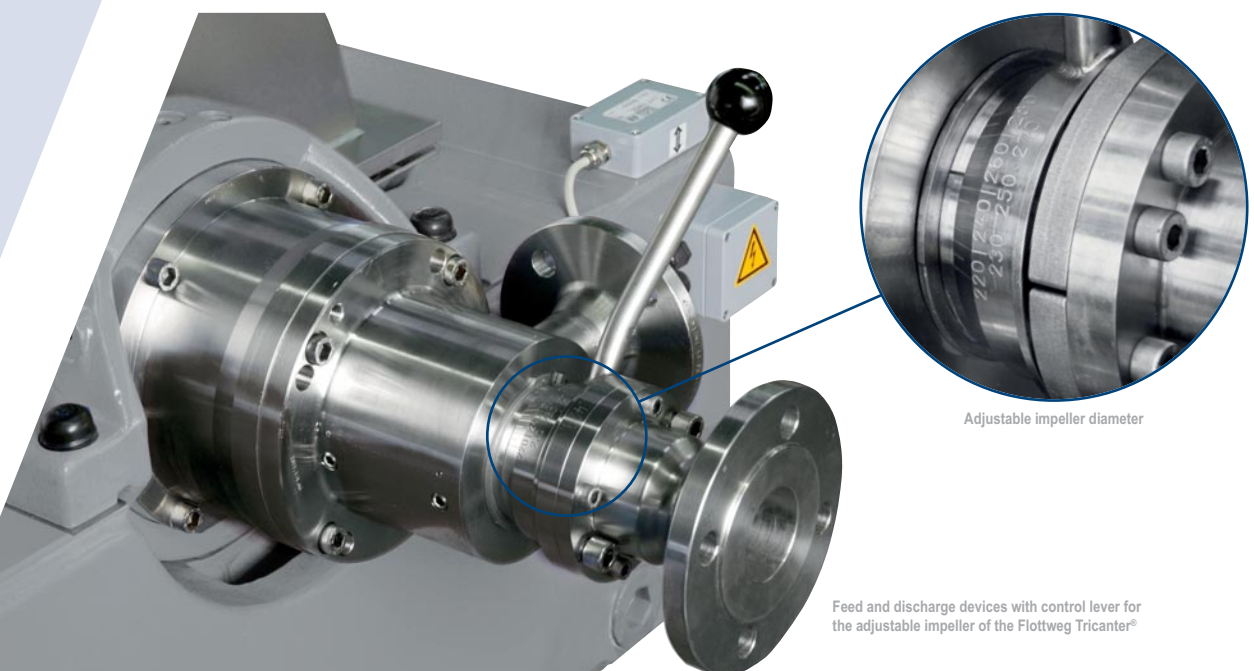



The innovative Flottweg Sorticanter® is designed for the separation of solids by density. The process is aided by a carrier liquid with a specific gravity that is between the densities of the two solid streams to be separated.

The patented Flottweg Sorticanter® consists of a cylindrical conical bowl with a second inner collection cone at the cylindrical end of the machine and a double acting scroll conforming to the inner collection cone.

The bowl and the scroll rotate at a high speed in the same direction, but the scroll rotates at a slightly faster differential speed. The solid-liquid mixture is conveyed through the centrifuge feed

pipe and inlet ports in the scroll body into the bowl and is accelerated to the bowl speed. Centrifugal force causes the solids which are heavier than the carrier liquid to settle against the bowl wall. The scroll conveys the deposited layer of heavy solids toward the conical bowl section, over the drying zone and ejects them through ports into the stationary solids housing and down the discharge chute.

The solids which are lighter than the carrier liquid float and are conveyed with the liquid toward the cylindrical end of the bowl. When the floating particles have reached the inner collection cone, scroll flights, wound in the opposite direction to those conveying sedimented solids, convey the lighter solids across a drying zone to the exit ports.

The liquid is skimmed off and discharged under pressure via an impeller at the cylindrical end of the bowl. The liquid may be recycled and pumped back into the process.

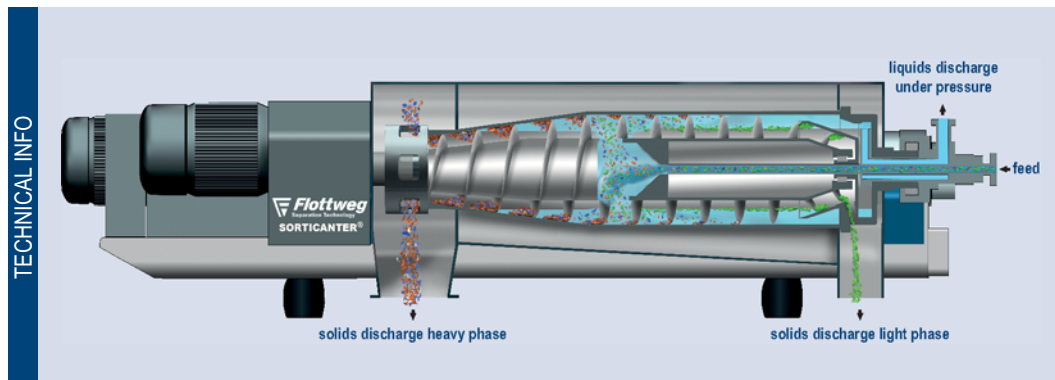

Flottweg Sorticanter® for plastic recycling



Plastic cuttings to be sorted using the Flottweg Sorticanter®

# FLOTTWEG SEDICANTER®

The Flottweg Sedicanter® is used for the separation of solids from liquids when the solids form a soft to flowable sediment.

The Sedicanter® is used in cases where the solids are too fine to be processed in a normal decanter and the sediment cannot be easily discharged from the decanter due to its soft consistency. During the separation process, the liquid and the solids move in the same direction without having to pass through a turbulent inlet zone. The centrate is discharged through an adjustable impeller. The sediment accumulates in the Sedicanter®, and is then hydraulically pressed out of the bowl beneath an immersion disc.

Applications for the Sedicanter® include “soft products” such as bio-masses, yeast suspensions, protein suspensions, fermentation broths, and many more.

## Technical features

- Up to 10,000 x g centrifugal force possible to facilitate the separation of very fine, slowly settling solids
- Uniquely designed feed distributor and bowl seal to prevent foaming in the product inlet zone
- Gastight machine design (optional)
- Clean-in-place provisions available to meet pharmaceutical industry standards
- Fluoropolymer rotor seals available for critical applications
- Optional drives including the Flottweg Simp Drive®

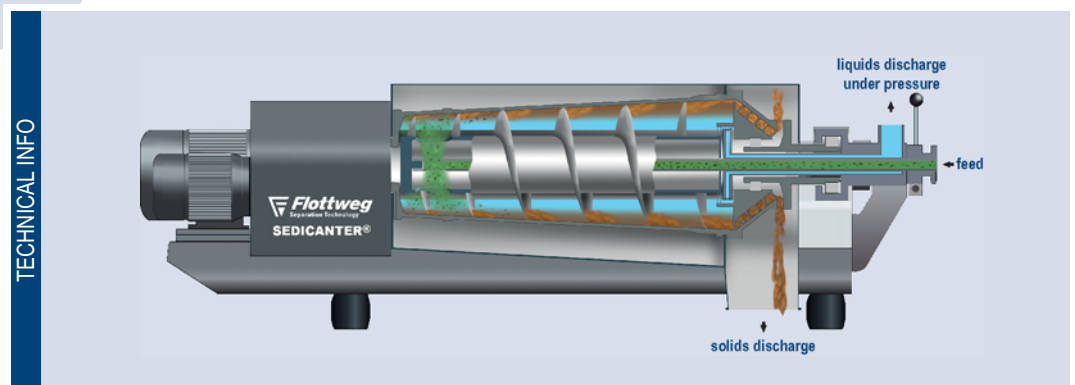

Flottweg Sedicanter®



Centrifuges are usually flushed clean before shutdown. Depending on the application, different cleaning systems may be incorporated into the centrifuge design. Flottweg Centrifuges are designed for continuous operation and do not have to be opened for cleaning. Flottweg Centrifuges for pharmaceutical, biotech and food processing applications are designed for the integration into Clean-in-Place (CIP) systems.

## CLEANING OF CENTRIFUGES FOR STANDARD APPLICATIONS

For the majority of applications (e.g. waste water, separation of crystalline products), it is sufficient to flush the centrifuge before shutdown through the feed pipe to remove deposits of solids. The flushing time and the type of cleaning fluid are product-dependent. In most cases the use of solids-free centrate will be adequate. Additional rinsing nozzles for cleaning the housing, the bowl exterior and the scroll interior can be installed if requested.

## CLEANING OF CENTRIFUGES FOR PHARMACEUTICAL, BIOTECH AND FOOD PROCESSING APPLICATIONS

The requirements for efficient cleaning are particularly high in the biotech, pharmaceutical and food industries. Flottweg designs its centrifuges to meet the rigid cleaning requirements in these industries.

### Characteristic features of centrifuges which meet hygienic requirements are:

- All welds are ground to meet specific sanitary finish standards (optional)
- All product wetted parts are provided with a surface finish in accordance with specified surface roughness values
- Spray nozzles are provided for the centrifuge housing and for the interior of the scroll body
- The centrate impeller is adjustable to facilitate the flushing of the bowl
- Frequency-controlled drives for CIP-cleaning at low speed
- Electropolished scroll, housing and bowl surfaces (optional)



# DRIVES

## GENERAL

Decanter centrifuges are subject to two basic drive requirements. First, the entire rotor has to run at high speed, and second, the scroll inside the bowl has to rotate at a very low differential speed and simultaneously at a high torque relative to the bowl wall. Flottweg frequency controlled electric motors or speed adjustable hydraulic motors offer infinitely variable speed. Long acceleration times help overcome a high inertia moment and avoid peak electric loads during the initial current phase. Depending on the application, Flottweg offers hydraulic motors or gear drives to drive the scroll. The majority of the drive configurations offer variable differential speeds. This ensures optimum adjustment to meet individual customer requirements.

## FULLY HYDRAULIC DRIVE

The bowl and the scroll are driven by separate hydraulic motors. A characteristic feature is the hydraulic motor which rotates together with the bowl and which directly powers the scroll, where the bowl is driven by V-belts. A compact hydraulic aggregate with two variable pumps feeds two separate oil circuits. The volume flow rate of the oil determines the bowl speed and the differential speed of the scroll, where the oil supply pressure is directly proportional to the torque output and thus to the load. The drive's design enables independent rotation of the scroll even when the bowl is shut down.

## HYBRID DRIVE

In this version, a frequency drive controlled electric motor drives the bowl instead of a hydraulic motor. The hydraulic aggregate for the scroll is compact because only one oil circuit is required. Control and adjustment are the same as with the hydraulic drive.

### Advantages of hydraulic drives

- Self-contained control aggregate
- Eliminates the need for VFD's and electrical drive motors on the machine in explosion-proof environments if this is preferred

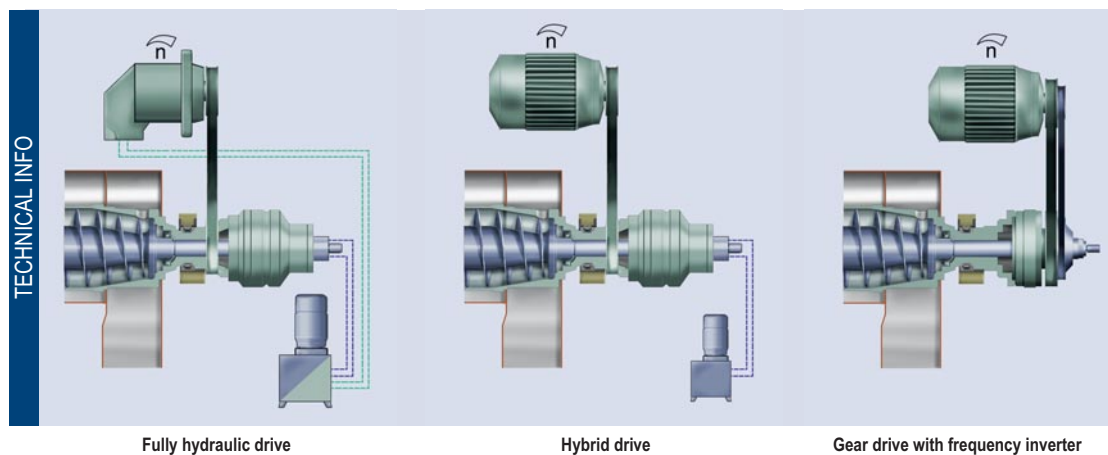

### GEAR DRIVE WITH FREQUENCY INVERTER

A frequency-controlled electric motor drives the bowl via a V-belt drive. A second parallel V-belt drive with a slightly different transmission ratio powers a cycloid planetary gear box and generates the differential speed of the scroll. The differential speed can be changed and adjusted by changing V-belt pulleys. The Flottweg gear drive is the most basic type of drive and is particularly suited for separation processes which do not require operating adjustment of the differential speed.

### BACKDRIVE WITH DUAL-VFD

This drive is derived from the Flottweg gear drive in which the scroll drive has its own frequency-controlled motor. The differential speed can be adjusted separately within a preset range and the control and monitoring can be load-dependent. Both drive motors are powered by a Flottweg frequency inverter, which is power-linked via a regenerative circuit. This drive is best suited for high differential speeds.

### SIMP DRIVE®

The Flottweg Simp Drive® controls the differential speed in relation to the scroll torque. Therefore, the decanter adapts itself to varying load conditions and dewateres the product until maximum cake dryness is reached. The main feature of this new concept is a multistage planetary gear which allows for entirely independent operation and drive of the bowl and scroll.



### Advantages of the Simp Drive®

- High efficiency and low energy demand
- Low power draw
- A simple drive system not requiring linkage
- Constant drive, constant torque
- Simple integration into process control systems
- Smallest possible inverter size
- Frequency inverters which are standard designs
- High flexibility in the selection of the operating speed
- Discharge of the bowl even at standstill
- Applicable for small to medium differential speeds

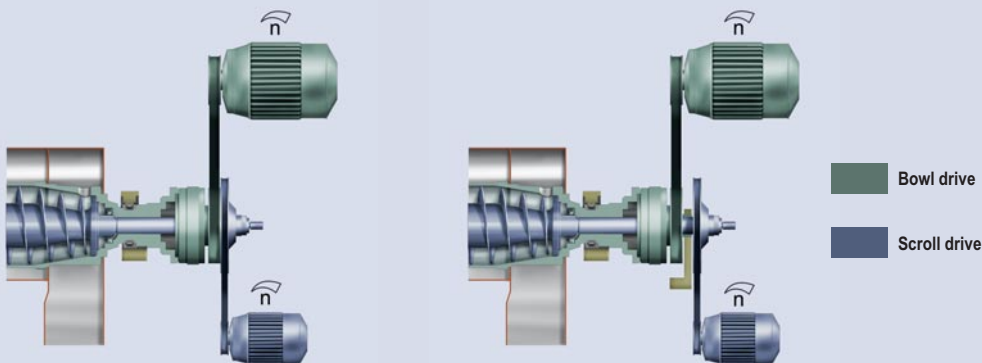

Backdrive with Dual-VFD

Simp Drive®

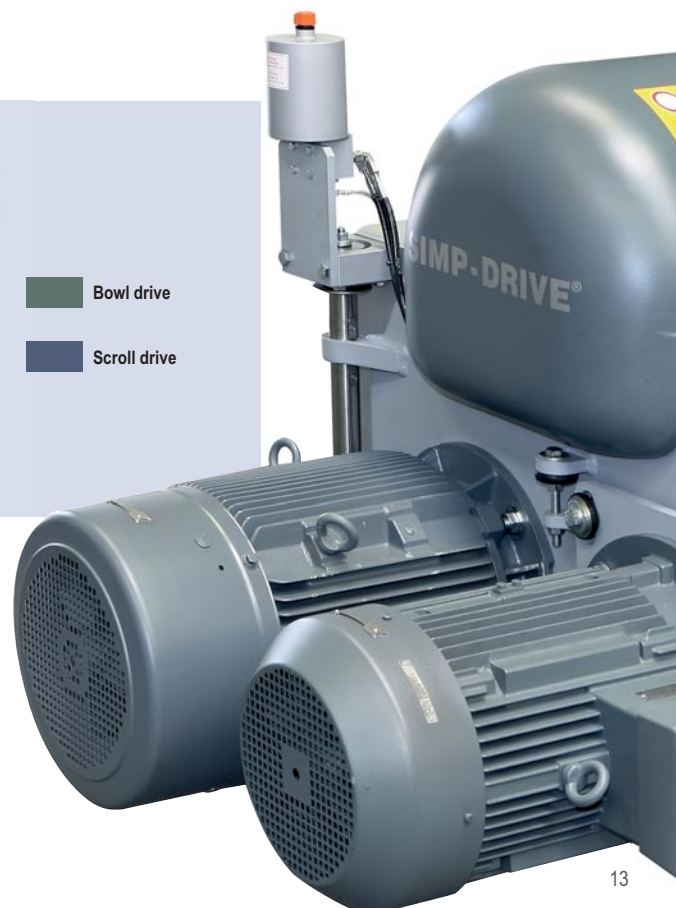

# SCROLL AND DIFFERENTIAL SPEED CONTROL SYSTEMS AND OVERLOAD PROTECTION

Fluctuations in the solid concentration and throughput may cause a decrease in separation results, a machine blockage, or an overload of the centrifuge. To avoid problems and to fully utilize the capacity of the centrifuge, the differential speed needs to be continuously monitored and adjusted to the operating conditions.

Flottweg offers control systems for the differential speed which are based on the following principle:



- 1) The scroll torque is an indicator of the bowl solids load.
- 2) The load, and therefore the torque, should be kept at an optimum value.

If the torque exceeds the optimum value, the Flottweg control system increases the differential speed to more quickly convey the solids out of the bowl until the torque decreases. Conversely, the differential speed is reduced when the torque decreases. This automatic control process ensures optimum separation during normal operation.

If a disruption in the system develops, an integrated two stage overload protection offers excellent security against clogging of the machine: If the increase in differential speed is not sufficient to compensate for a solids overload, the feed supply is stopped until the torque falls back below the set point. In the majority of situations, this is sufficient to remedy the overload without having to shut down the system. If this step is insufficient to keep the scroll torque from rising, the bowl drive is shut down when the torque reaches the second higher set point. As the bowl speed decreases, the torque is reduced and the machine will usually empty itself. Typically there is no need to manually remove the solids. Machines with a hydraulic drive or Simp Drive® allow for solids discharge at full scroll torque even when the bowl is shut down.

TECHNICAL INFO



	Decanter	Feed												
Scroll	Bowl	Lubrication												
Power of the Bowl	27.1 kW													
Bowl Speed	3957 rpm													
Set Point	100.0 %													
Bowl Speed Min	500 rpm													
Differential Speed Min	0.5 rpm													
		<b>Bearing Temperatures</b> <table style="width: 100%;"> <tr> <td></td> <td style="text-align: right;">Actual Value</td> </tr> <tr> <td>Drive End</td> <td style="text-align: right;">42 °C</td> </tr> <tr> <td>Feed End</td> <td style="text-align: right;">38 °C</td> </tr> <tr> <td>Pre-Alarm</td> <td style="text-align: right;">120 °C</td> </tr> <tr> <td style="text-align: center;">+</td> <td style="text-align: right;">10 °C</td> </tr> <tr> <td style="text-align: center;">=Alarm</td> <td style="text-align: right;">130 °C</td> </tr> </table>		Actual Value	Drive End	42 °C	Feed End	38 °C	Pre-Alarm	120 °C	+	10 °C	=Alarm	130 °C
	Actual Value													
Drive End	42 °C													
Feed End	38 °C													
Pre-Alarm	120 °C													
+	10 °C													
=Alarm	130 °C													
  														

Flottweg Touch Control

Flottweg assures for optimal coordination of the control system with the centrifuge. Only the OEM has the complete knowledge of all technical details, and is thus able to avoid interfaces with undefined responsibilities. After a time-efficient start-up, the centrifuge gets perfectly integrated into your process and the full capacity of production can be reached without delay.

As the manufacturer of our control panels, we can fulfill nearly all customer specific requirements. Adaptations to new requirements can be achieved easily. The extensive testing of our control systems before delivery in our facility avoids delays at start-up and enables the customer to get the production up to speed quickly and efficiently.

With the help of our know-how and the experience as a manufacturer of centrifuges, you can be certain that all of your future challenges can be solved quickly and easily.

## Optimal integration and operation – customized to your process

**Your advantages:**

- Optimal integration of the centrifuge’s control panel into your control system is a necessity for high efficiency and safe operation of your plant.
- Easy and self-explanatory operation of the Flottweg Touch Control minimizes down time due to operating errors.
- Systems are equipped with connections that allow for all options of remote maintenance/control. This avoids unplanned down time and minimizes operating costs.
- All functionalities and signals are tested before delivery, which facilitates the start-up process and gets your production up to speed quickly.
- Highest possible safety is accomplished via compliance with all relevant ISO and EN regulations as well as our comprehensive Factory Acceptance Test.
- Fast and world-wide availability of spare parts is obtained by using standard components.

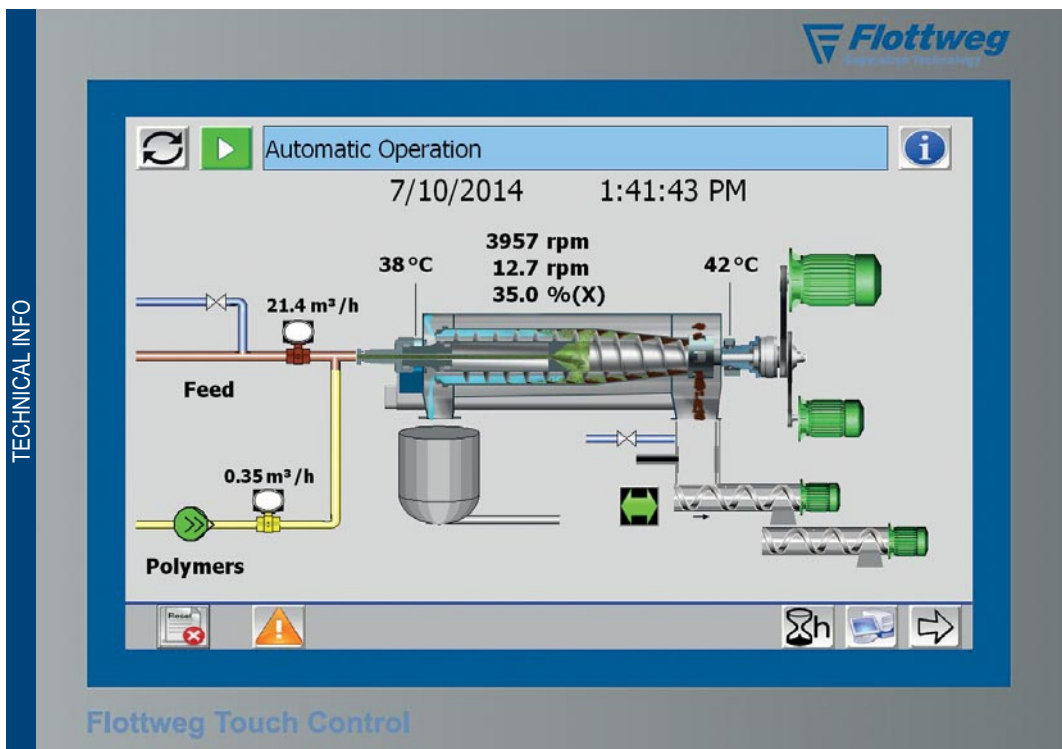

Flottweg Touch Control

# SEALING SYSTEMS

Most sizes and models of Flottweg Centrifuges are available in a variety of rotor and housing seal designs for the following operating conditions:

- Atmospheric
- Vapor-tight
- Gas-tight

Flottweg Centrifuges can also be adapted for operating in closed-loop systems.

## ATMOSPHERIC CENTRIFUGES

are the standard version. They are used for applications where there is no harm from products or vapors released to the environment.

## VAPOR-TIGHT VERSIONS

Flottweg Centrifuges are the right choice in cases where substances emitted from the process could pollute the environment if contact of the product with ambient air is undesirable. Additional seals on rotor shafts and housings provide the necessary seal. Emissions can be eliminated when purge gas/air is applied to seals or when the centrifuge housing is vented.

## GAS-TIGHT CENTRIFUGES

allow for safe operation with toxic, corrosive or flammable media by applying inert purge gas to rotor seals and by inertizing the process chamber and centrifuge housing. Slight positive or negative pressures can be maintained in the process area by regulating the purge gas supply. Special sealing elements minimize the seal gas consumption.

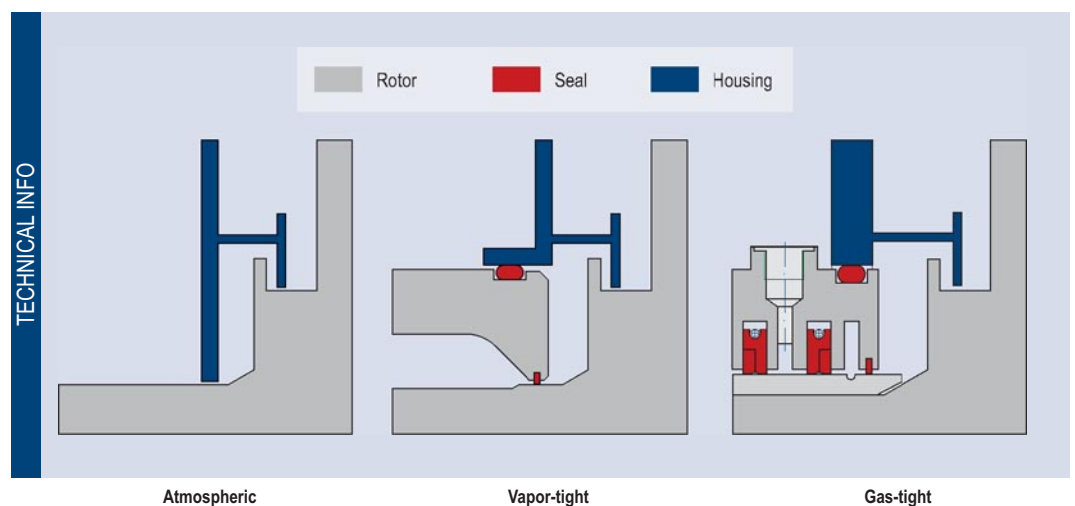



# PURGING

## With Inert Gas

### PROCESSING HAZARDOUS MATERIALS

If centrifuges are used to process products whose vapors together with oxygen may form a flammable suspension, any risk of explosion must be avoided by substituting air with inert gas. Generally, nitrogen is used. Centrifuges and system components used for the processing of hazardous materials have to be gastight to prevent the exit of vapors into the atmosphere as well as to avoid the entry of air into the system. Typical examples are processes in the chemical, petroleum, and pharmaceutical industries, or processes with flammable organic solvents or those involving oil sludge treatment. These centrifuges comply with ATEX 95 in Zone 1 or Class 1, division 1, up to temperature class T3.

### PURGING

Before starting, the entire system, including the centrifuge, is purged. In order to do this, large volumes of inert gas are flushed through the system until the amount of oxygen is reduced to a non-critical and safe level. Purging is complete if the amount of inert gas delivered to the system reaches a multiple of the system volume, or if an oxygen probe at the centrifuge housing shows a safe oxygen concentration.

### BLANKETING

After successful purging and during operation with the product, sufficient inert gas is fed into the system to ensure a small overpressure. This prevents atmospheric air from penetrating into the system.

### CONTROL OF CENTRIFUGES PURGED WITH INERT GAS

is accomplished with a differential pressure monitoring system with integrated automatic control. Thus, a fixed overpressure in the sealing system is constantly maintained using control valves. Manual readjustment is not required anymore. This method ensures a small overpressure within the sealing system and the inside of the centrifuge guaranteeing protection against air leakage into the system and product emission into the atmosphere.

### PROCESSING OF MATERIALS SUSCEPTIBLE TO OXIDATION

In particular, processing beverages and food requires that the product is prevented from undergoing oxidation. For this purpose, the leakage of air into the centrifuge is prevented with relevant design features and the centrifuge is purged with inert gas. In many cases, carbon dioxide is used as inert gas. A system monitoring the flow of gas is commonly used.



Flottweg Control Unit for the purging and blanketing with inert gas

# LUBRICATION

Flottweg Centrifuges can be provided with different lubrication systems according to customer requirements. The lubrication system depends on the type of operation, for example, batch or continuous operation and the degree of automation of the entire system. Flottweg Lubrication Systems allow for the re-lubrication of rotor bearings during operation. The availability of the different lubrication systems depends on the centrifuge model.

## MANUAL LUBRICATION

Direct lubrication at both rotor bearing blocks via a manual grease pump.

## CENTRAL LUBRICATION SYSTEM

Lubrication from a central manually operated pump. The lubricant is accurately dispensed through a piston distributor to the designated greasing points.

## AUTOMATIC GREASE LUBRICATION

In contrast to the manual central lubrication system, the greasing system can be operated automatically. This ensures uniform and reliable lubrication of the centrifuge. It prevents bearings from being under- or over-lubricated and eliminates short-term spikes in bearing temperatures and excessive grease consumption. The function of the grease pump is controlled by the control system. For the most stringent requirements, an oil-air lubrication system can be provided.

## AUTOMATIC OIL DROPLET LUBRICATION SYSTEM

The fully automatic oil-air lubrication system ensures for minimal quantity lubrication with oil droplets transported via a stream of air to the bearings. Optimal lubrication is achieved at high speeds, with low oil consumption and no loss in performance. Monitoring of the oil and air pressure guarantees high operational safety. Pneumatic designs are available for utilization in explosion-hazardous areas. They are suited for Zone 1 up to temperature class T4 according to ATEX 95.



Central lubrication system (manually)



Automatic grease lubrication



Oil-air lubrication system

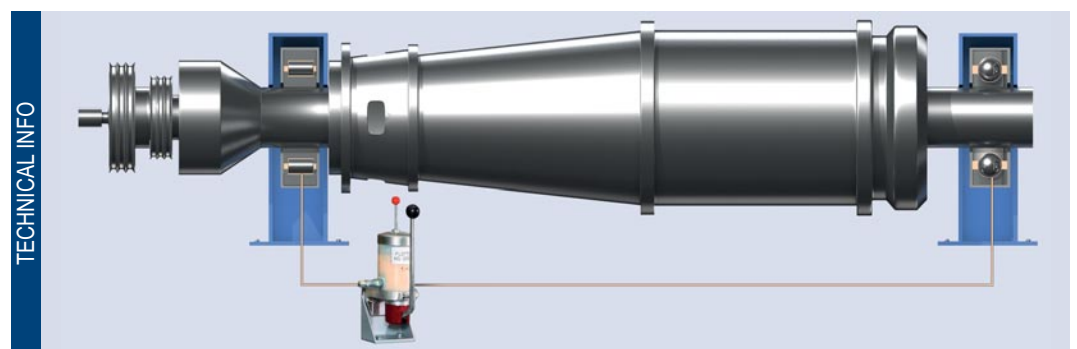

Rotor bearings lubricated via the central lubrication system

TECHNICAL INFO

Flottweg offers a wide range of wear protection to meet the requirements of the many different applications in which centrifuges are installed:

- 1) Welded hard facing or spray coating
- 2) Ceramic
- 3) Tungsten carbide tiles
- 4) Chilled hard metal portcastings
- 5) Plastic liners

In order to minimize maintenance costs for applications involving highly abrasive products, all wear protection elements, except welded hard facings or spray coatings, are field replaceable.

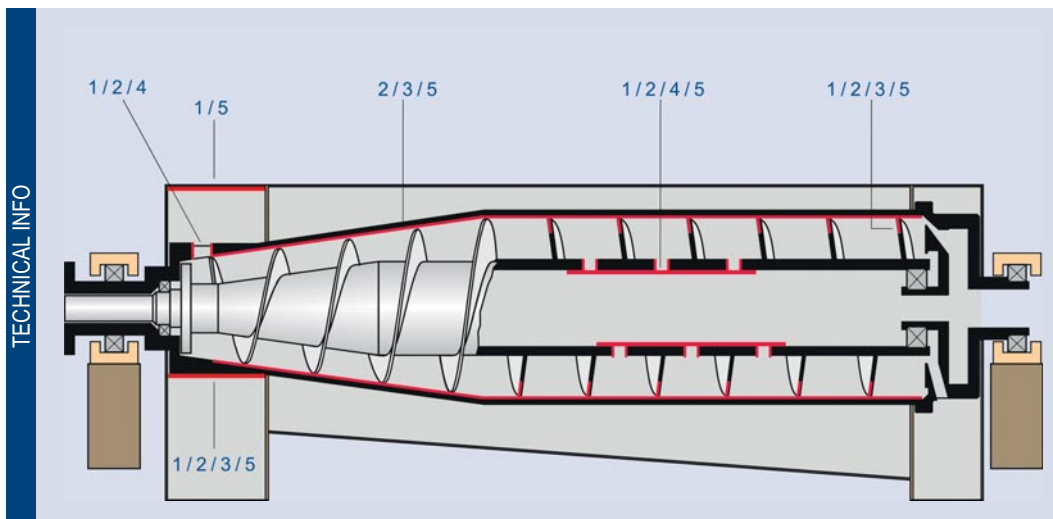

Replaceable wear protection elements



# DECANTER CONTROL

## VIBRATION MONITORING (STANDARD)

Vibration sensors transmit acceleration signals to an analyzer that sounds an alarm or shuts the centrifuge down upon reaching the maximum permissible level.

## SPEED MONITORING (STANDARD)

Bowl speed and scroll differential speed are each measured by an inductive proximity switch and shown on a digital display. Continuous monitoring of maximum and minimum values during operation helps to minimize preventable failures and maintain acceptable safety standards.

## TEMPERATURE MONITORING (OPTIONAL)

Bearing temperatures are continuously monitored on Flottweg Centrifuges by means of resistance thermometers. Upon exceeding pre-set temperature limits – between 100°C and 130°C depending on the individual application - , the centrifuge gives an alarm or shuts down. This preventive measure safeguards against bearing failure or machine damage.



Vibration monitoring (standard)

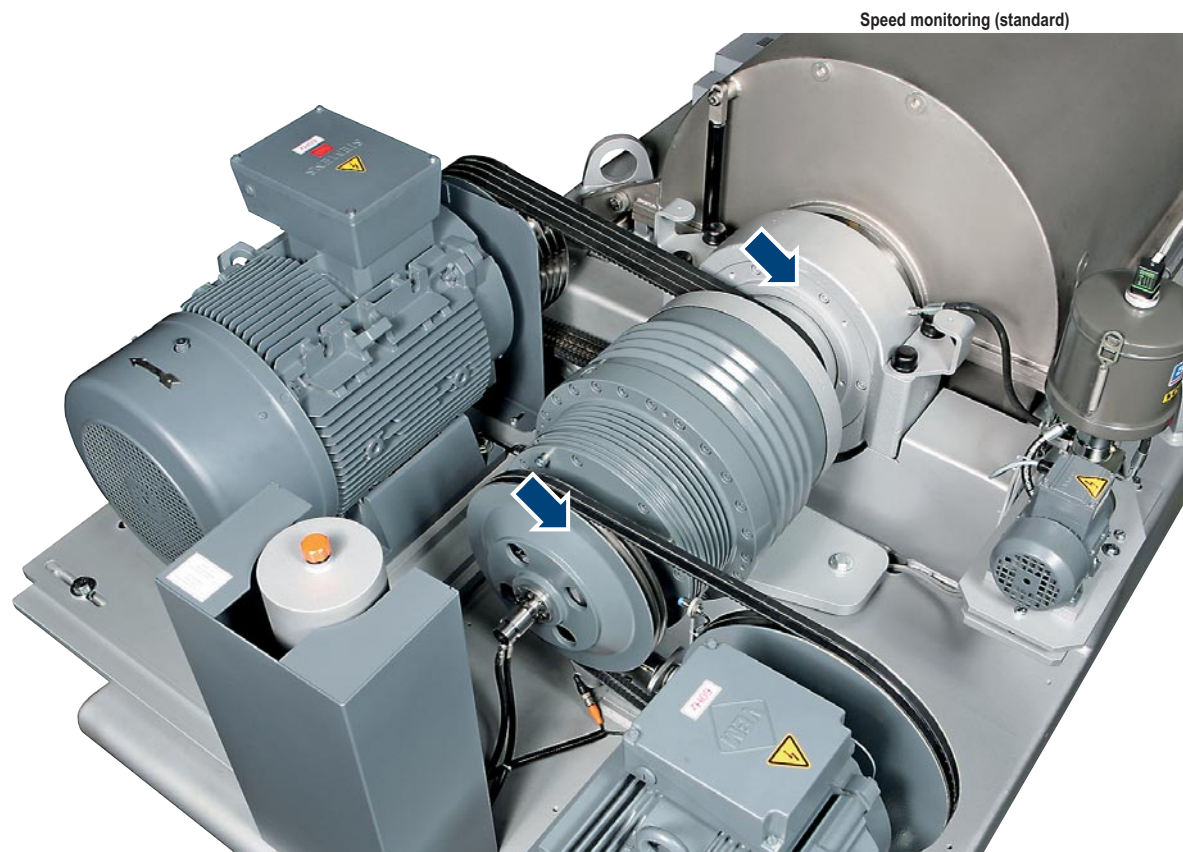

Speed monitoring (standard)

## CUSTOMER SERVICE IS OUR STRENGTH

Application-based project planning, high-quality manufacturing and professional after-sales service are prerequisites for a trouble-free operation. Experienced and reliable service engineers from our customer service department are ready to respond quickly if needed. The Flottweg Service Group is also available to perform preventive maintenance in order to avoid interruptions in production.

## QUALITY “MADE IN GERMANY”

Flottweg is ISO 9001 certified and manufactures its products in compliance with the latest technical standards.



## Flottweg Services include:

- Experienced advice on separation processes
- Pilot tests on-site or at the Flottweg Laboratory and Test Center
- Selection and sizing of appropriate equipment
- Customer-specific automation/control systems and process integration
- Design and construction of complete process systems
- Installation, commissioning, maintenance, repair and spare parts service worldwide

## Service hotlines

Phone: +49 8741 301-0  
 Fax: +49 8741 301-404  
 From 5 p.m. to 7 a.m.  
 Tel./fax: +49 8741 91591



Flottweg Mobile Test Unit

## FLOTTWEG AFTER-SALES CUSTOMER SERVICE

Even the best machinery needs to be maintained and serviced. Flottweg has established a worldwide service network consisting of its own subsidiaries, branch offices, and representatives to provide our customers with localized service and spare parts.

Our service engineers and technicians are qualified for any kind of installation, commissioning, repair and maintenance.



Flottweg Service Technicians are always available for you

# SOLID BOWL CENTRIFUGES PRODUCT LINES AND MODELS

Decanter C-Series, Sorticanter® and Sedicanter®

Decanter  
C-Series

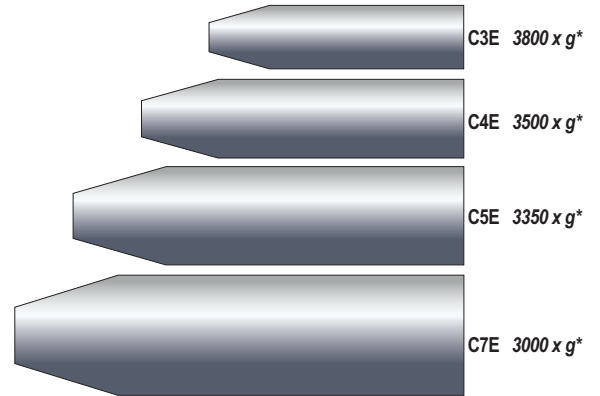

Sorticanter®

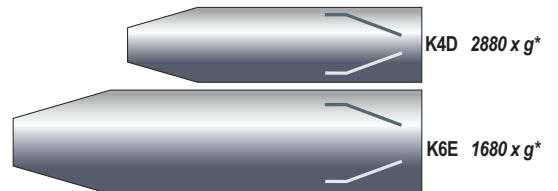

Sedicanter®

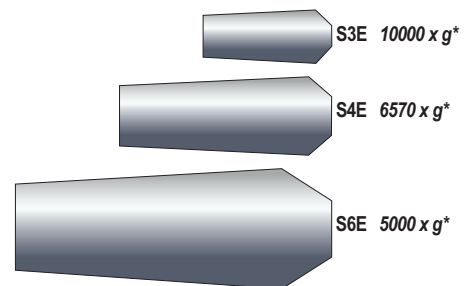

\*Acceleration in g, depending on the temperature and the density of the product

# Decanter Z-Series and Tricanter®

Decanter

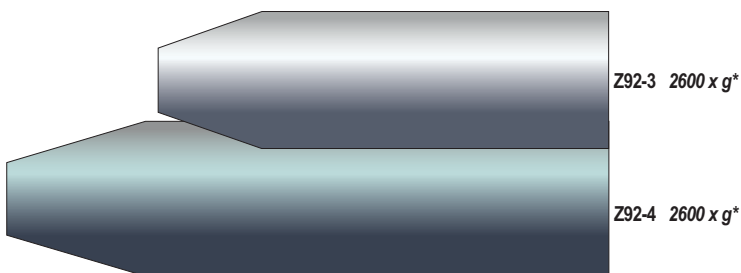
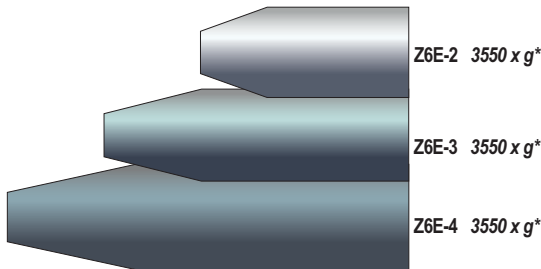
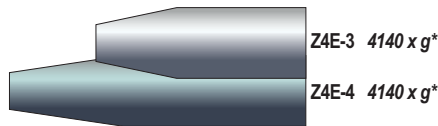
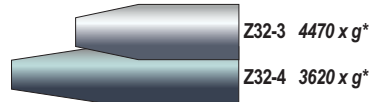
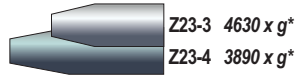

Tricanter®

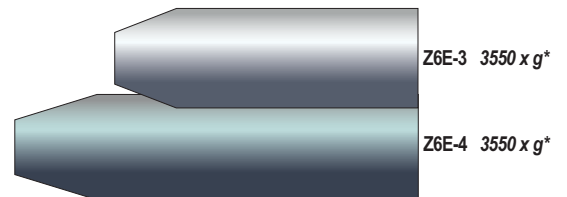
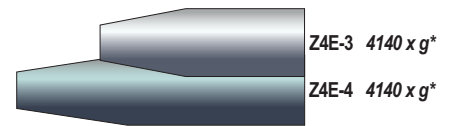
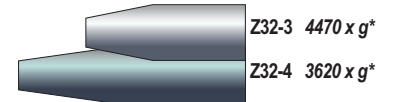
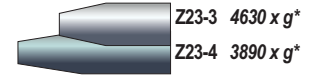

# Flottweg Separation Technology – Engineered For Your Success



Flottweg SE  
Industriestraße 6-8  
84137 Vilsbiburg  
Deutschland (Germany)

Tel.: +49 8741 301-0  
Fax: +49 8741 301-300

mail@flottweg.com  
www.flottweg.com

REPRESENTATIVE